

PWT 63 C IP54

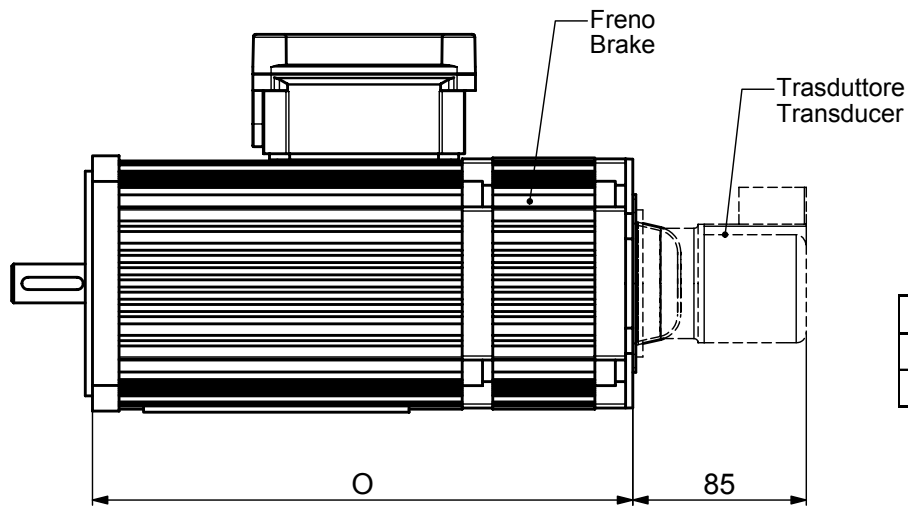
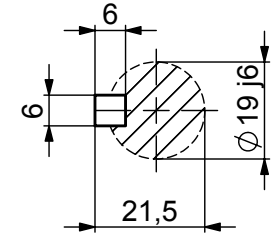
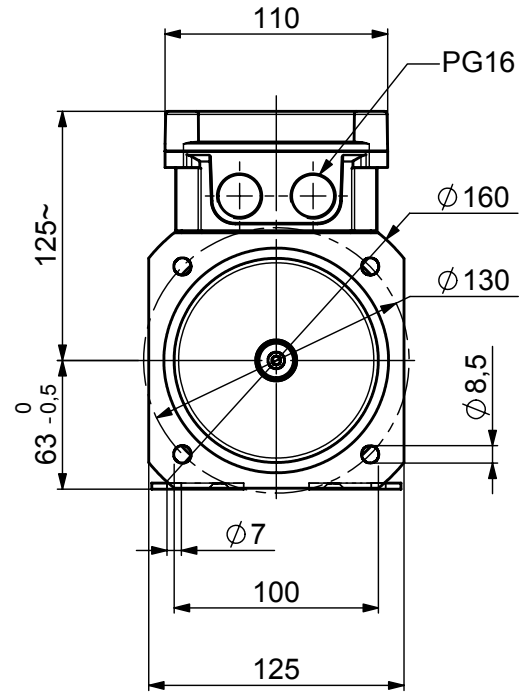
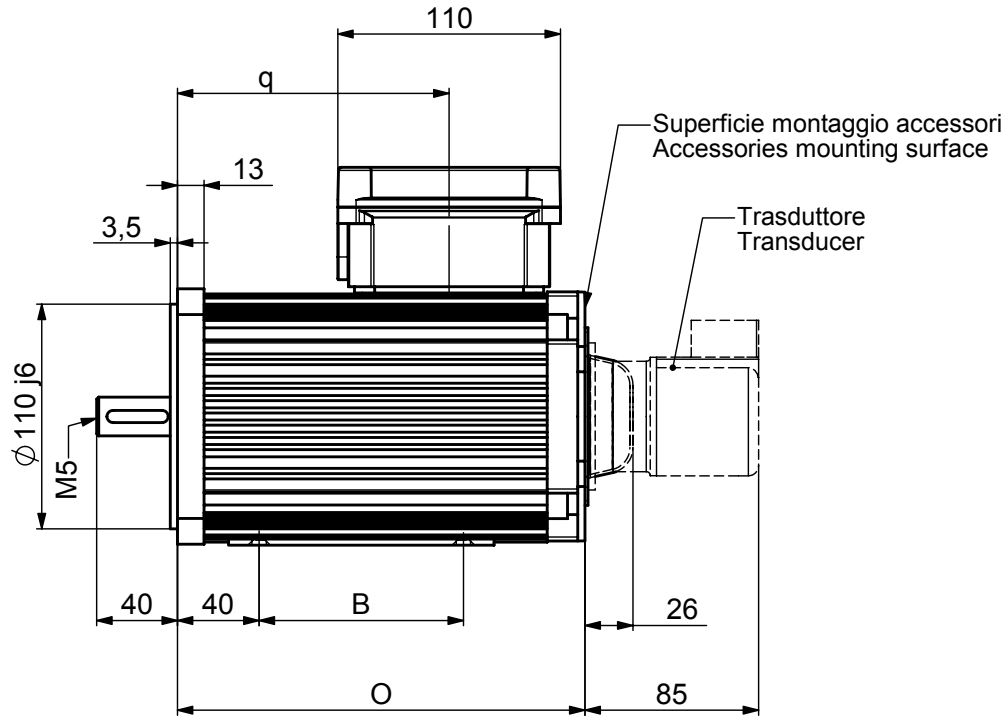

Motore -motor	q	B	VERSIONE NORMALE STANDARD VERSION		VERSIONE CON FRENO VERSION WITH BRAKE	
			O	Peso kg	O	Peso kg
63.1C	133	100	200	11	265	13
63.2C	208	175	275	15	340	17